

TA2020-020

APPLICATION / TEST CIRCUIT

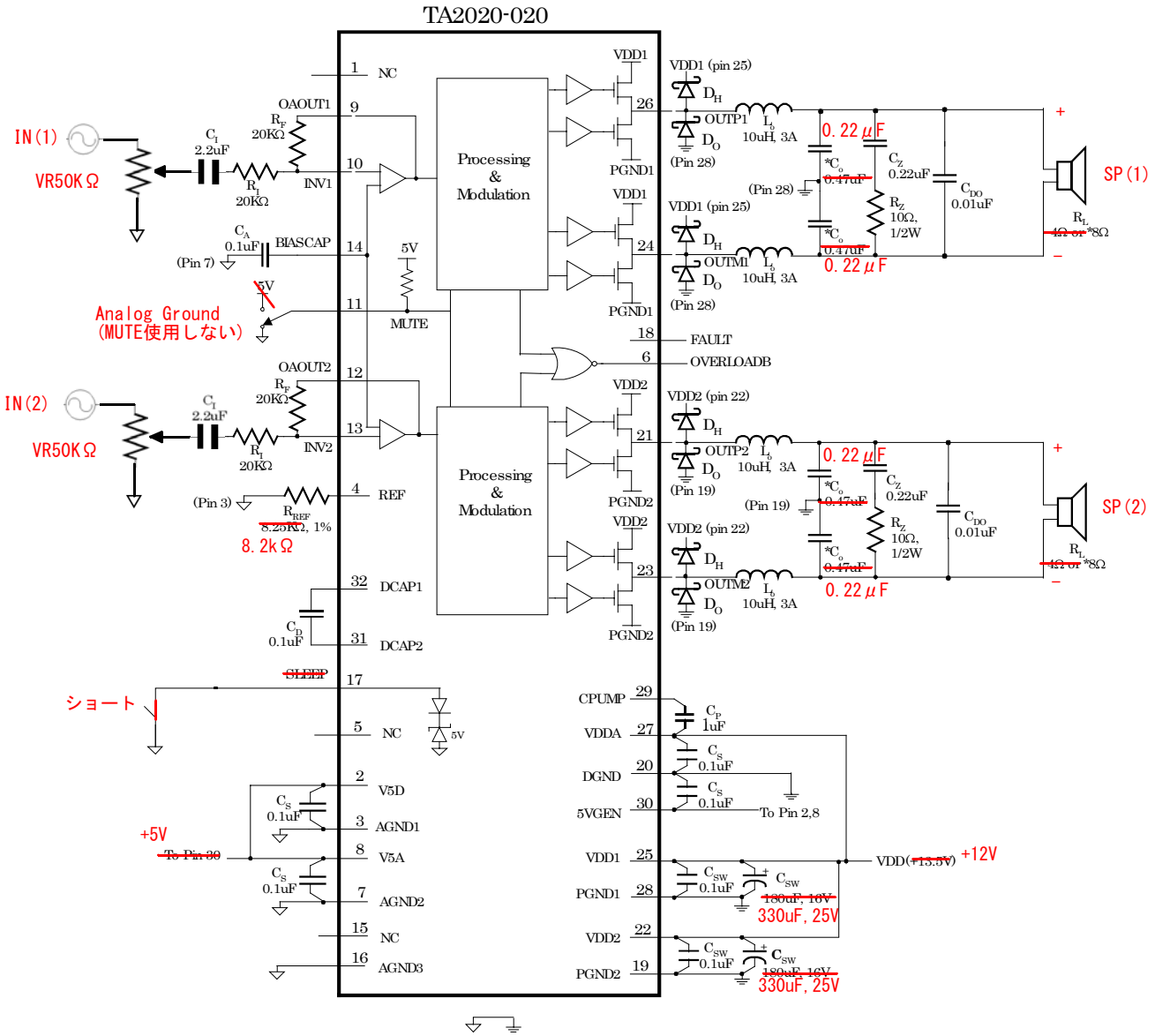

Note: Analog and Digital/Power Grounds must be connected locally at the TA2020-020

⏚ Analog Ground

⏚ Digital/Power Ground

Diodes (DO and DH) are Motorola MBRS130T3 (the DH diodes are required for $V_{DI} > 13.5V$)

*Use $C_o = 0.22\mu F$ and $C_z = 0.22\mu F$ for 8 Ohm loads

■電源■ (12V, 5V)

